

IceCold

Custom Counter

Keep it fresh, and keep it ice cold. Designed for product presentation on crushed ice, the IceCold full serve model is the ultimate choice for fresh products such as fresh fish.

The dehydration challenge

Dehydration is a common issue when presenting fresh unpacked products such as fresh fish. Our optional time-based misting system has been designed to tackle this. Achieve superior preservation and presentation by preventing dehydration and creating a wet surface look.

Custom Counter Configurator

Designing a tailor-made counter is easier than ever before with our Custom Counter Configurator. The Fri-Jado team is ready to assist you in configuring your perfect counter by using this tool. The configurator creates a counter that meets your exact needs and visualizes what this could look like in a 3D image.



Key Features Custom Counter IceCold

- OmniCold refrigeration system: products are surrounded by a cold airflow from all sides, guaranteeing optimal product temperatures under all conditions whilst saving energy
- Optional misting system (spray bar)
- Easily removable chilled ice tubs (no scooping required)
- Ice lasts all day thanks to mild airflow
- Optional coated rear evaporator coil
- Optional front lighting
- Large customizable worktop (280 mm) with optional accessory rail to mount cutting boards, sliding scale platforms, bag hooks etc.
- Various bumper options
- Customizable cladding and materials
- Integral or remote refrigeration
- Optional night covers
- Multiplexable with other Custom Counter models



Optional misting system



Customizable cladding and materials



Spray bar nozzles

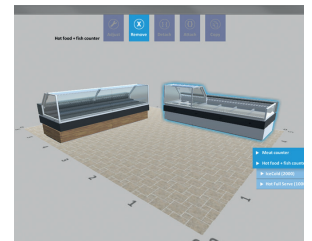

Custom Counter Configurator

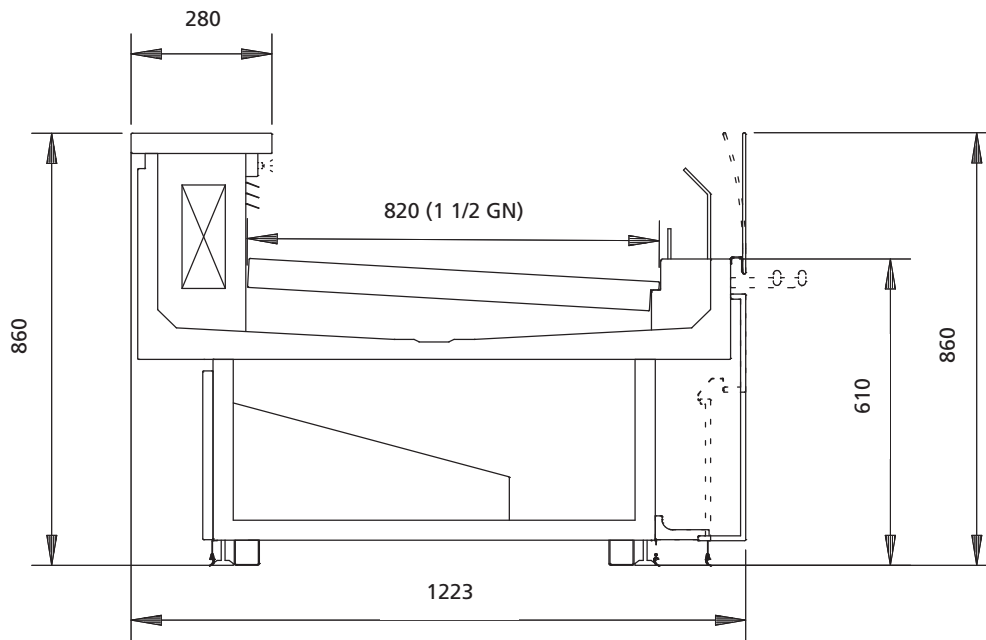

Technical specifications

Model	Ice Cold full serve, self serve
Length options (mm)	750, 1000, 1250, 1500, 1750, 2000, 2250, 2500, 2750, 3000, 3250, 3500, 3750*
Product temperature	- 1 < T < 3 °C
Presentation area depth	820 mm
Refrigeration capacity	< 400 W/m
Evaporation temperature	Up to - 4 °C
Nominal voltage	1N~230V 50/60Hz
Stacking height	Up to 180 mm
Glass	Curved or Unisquare (squared) lift-up glass
Technology	OmniCold: mild airflow, rear evaporator coil, chilled ice tub
Misting system	Spray bar (optional)
Refrigerant options (other refrigerants on request)	Remote Glycol, R404a, R407f, R744 (CO ₂) Integral R134a, R1234yf
Interior configuration	Chilled ice tubs
Interior material	Stainless steel AISI 316
Exterior	Customizable cladding and materials. Various bumper options.
Worktop	Large customizable worktop (280 mm) with optional accessory rail to mount cutting boards, sliding scale platforms, bag hooks etc.

* Minimum and/or maximum length may be limited by selected refrigeration and misting options.

** Depending on store temperature, interior configuration, stacking height and evaporation temperature.

Specifications and technical data are subject to amendment without prior notice. Please check www.frijado.com for the latest information and specifications.

Fri-Jado B.V.
P.O. Box 560
4870 AN Etten-Leur
The Netherlands
Phone +31 76 50 85 400
e-mail info@frijado.com
www.frijado.com