

# USER MANUAL – EU version

## Deli Counter – Hot



**WARNING**

Read the instructions before using the machine.

**KEEP THIS USER MANUAL FOR FUTURE USE!**

© 2024 Fri-Jado B.V., Oud Gastel, The Netherlands.

We advise you to contact your supplier for the guarantee period and conditions. Further we refer to our General Terms and Conditions for Sales and Delivery that are available upon request.

The manufacturer does not accept any liability for damage or injury caused by failing to adhere to these regulations or by not observing the usual caution or care in actions, operation, maintenance, or repair activities, even if not explicitly described in this manual.

As a result of constant commitment to improvement, it may happen that your unit deviates in detail from what is described in this manual. For this reason, the given instructions are only a guideline for the installation, use, maintenance, and repair of the unit referred to in this manual.

This manual has been composed with the utmost care. The manufacturer shall, however, not be held responsible for any mistakes in this manual nor for any consequences thereof.

The user is allowed to copy this manual for own use. Further all rights are reserved and nothing in this manual may be reproduced and/or made public in any way.

**Modifications:**

In case of unauthorized modifications in or on the unit, every liability on the part of the manufacturer becomes null and void.

# CONTENTS

<b>1.</b>	<b>INTRODUCTION .....</b>	<b>4</b>
1.1	General.....	4
1.2	Identification of the unit.....	4
1.3	Pictograms and symbols.....	4
1.4	Safety instructions .....	5
1.4.1	General.....	5
1.4.2	Moving (when applicable) .....	5
1.4.3	Outdoor use restrictions.....	6
1.5	Hygiene .....	6
1.6	Service and technical support .....	6
1.7	Storage.....	6
1.8	Disposal.....	6
<b>2.</b>	<b>DESCRIPTION OF THE UNIT .....</b>	<b>7</b>
2.1	Intended use.....	7
2.2	Technical description .....	7
2.3	Accessories .....	7
<b>3.</b>	<b>INSTALLATION AND FIRST USE .....</b>	<b>8</b>
3.1	Unpacking the unit .....	8
3.2	Installation and positioning.....	9
3.2.1	Level the unit .....	9
3.2.2	Mounting the plinths.....	10
3.3	Drop-in units .....	10
3.4	Plateau Options .....	11
3.5	Humidification system.....	12
3.5.1	Water connection.....	12
3.5.2	Manual filling system (optional).....	13
3.6	First use.....	13
<b>4.</b>	<b>OPERATION AND USE .....</b>	<b>14</b>
4.1	Operating.....	14
<b>5.</b>	<b>CLEANING AND MAINTENANCE .....</b>	<b>16</b>
5.1	Maintenance schedule .....	16
5.2	Daily Cleaning.....	16
5.3	Weekly Cleaning.....	16
5.4	Cleaning Glass Panes .....	17
5.5	Cleaning air guides, fans, and water tray .....	18
<b>6.</b>	<b>MALFUNCTIONS AND SERVICE .....</b>	<b>20</b>
6.1	Replace the mains cord .....	20
<b>7.</b>	<b>TECHNICAL SPECIFICATIONS .....</b>	<b>21</b>

## 1. INTRODUCTION

### 1.1 General

This is the user manual of the European models of the DC (Deli Counter) Hot. The features and controls, along with directions for the safest and most efficient use, for a long life of the unit.

All pictograms, symbols and drawings in this manual apply to all available DC Hot models.

### 1.2 Identification of the unit

The identification plate is on the outside of the machine, which contains the following data:

- Name of the supplier or the manufacturer
- Model
- Serial number
- Year of construction
- Voltage
- Frequency

### 1.3 Pictograms and symbols

In this manual, contains the following pictograms and symbols:

**WARNING**

Carefully follow the instructions to avoid possible physical injury or serious damage to the unit.

**WARNING**

Hazardous electrical voltage.

**WARNING**

Danger of getting injured by hot surfaces.

**SAFETY**

Wear safety gloves for installation and dismantling.



Suggestions and recommendations to simplify indicated actions.



Recycling symbol.

## 1.4 Safety instructions

**WARNING**

The outside and shelves of the unit can be very hot.

**WARNING**

The maximum load on top of the unit may never exceed 10 kg.

**WARNING**

See installation instructions for grounding requirements.

### 1.4.1 General

The user of the unit will be fully responsible for abiding the locally prevailing safety- rules and regulations.

Only qualified and authorized persons may operate the unit. Anyone working on or with this unit must be familiar with the contents of this manual and carefully follow all guidelines and instructions. Never change the order of the steps. The management must instruct the personnel based on this manual and follow all instructions and regulations.

The pictograms, labels, instructions, and warning signs attached to the unit, are part of the safety measures, do not cover or remove them. They have to be clearly visible during the entire lifetime of the unit.

Immediately repair or replace damaged or illegible pictograms, warnings, and instructions.

- **WARNING** there is a possibility the floor is slippery adjacent to the appliance. Due to the overflow of water.
- To avoid short-circuiting, never clean the unit using a water hose. For cleaning instructions, see chapter 5.
- The glass and back of the hot unit can get hot.
- Cleaned the unit regularly to ensure proper functioning.
- Do not store explosive substances such as aerosol cans with flammable propellant in this appliance.
- This appliance can be used by children aged from 8 years and above and persons with reduced physical, sensory, or mental capabilities or lack of experience and knowledge if they have been given supervision or instruction concerning use of the appliance in a safe way and understand the hazards involved.
- Children shall not play with the appliance.
- Cleaning and user maintenance shall not be performed by children without supervision.

### 1.4.2 Moving (when applicable)

When moving the unit:

- Before moving the unit, first pull the plug from the wall socket to switch off the mains voltage.
- Remove pans containing a liquid product from the unit.
- Always keep the unit in upright position.

### 1.4.3 Outdoor use restrictions

**WARNING**

To avoid short-circuiting, do not use the units outdoors or in a rainy or very moist environment.

### 1.5 Hygiene

**WARNING**

Immediately remove products in damaged packaging from the equipment and destroy the products. Clean all components that have come in contact with products from damaged packaging.

The quality of a fresh product always depends on hygiene. Prevent fresh raw vegetables or already prepared, cooled products from coming into contact with raw meat products to avoid transmitting salmonella. First thoroughly clean hands and/or tools that have touched raw meat. The core temperature of the products at loading should at least be 85°C.

Be aware that high humidity levels may encourage the growth of biological organisms in the unit.

Refer to the cleaning instructions of section 5.

### 1.6 Service and technical support

The unit includes the electrical schematics. In case of malfunctions, contact the dealer/service agent. Make sure the following data from the identification plate is available:

- Model
- Serial number

### 1.7 Storage

The following instructions are for the storage of units that are temporarily not in use:

- Clean the unit thoroughly
- Wrap the unit from getting dusty
- Store the unit in a dry, non-condensing environment
- Ensure good ventilation
- Humidified models: empty water tray

### 1.8 Disposal



Dispose of the machine, or any components removed from it safely in accordance with all local and national safety and environment requirements.

## 2. DESCRIPTION OF THE UNIT

### 2.1 Intended use

Use the DC Hot for the presentation and holding of (un)packed foodstuff. The DC uses a gastronorm frame or product deck for the presentation of foodstuff. Any other use will not be considered as the intended use of this machine.

The manufacturer accepts no liability whatsoever for loss or injury caused by failing to strictly adhere to the safety guidelines and instructions in this manual or due to carelessness during installation, use, maintenance, and repair of the unit referred to in this manual and any of its accessories.

Use the unit in perfect technical condition only.

### 2.2 Technical description

DC hot units have a heat source in the base of the cabinet and use fans to distribute the heat throughout the cabinet. An electronic thermostat controls the temperature. The electronic thermostat has been set at the default value at the factory. The thermostat has a range between 40°C and 90°C. The units have radiant ceramic heaters which have an individual on and off switch. LED lights provides for lighting of the products. The LED-lighting and the heating have separate on and off switches. The units have a humidification system in the form of a passive water tray, which require a water inlet.

On the operator side of the unit is the control panel.

The metal panels are galvanized steel, stainless steel, or aluminium. The frame of the unit is powder-coated steel. The windows are tempered glass or laminated glass. The product-contact parts are made of stainless steel AISI 304 or AISI 430, powder coated metal and tempered glass.

Use a pallet truck to move the unit.

Contact Fri-Jado to receive advice for optimizing the hot food operations.

### 2.3 Accessories

The unit contains the following standard accessories:

- User manual,
- Plinth set. (When supplied on an underframe)

For optional accessories contact [customer.service@frijado.com](mailto:customer.service@frijado.com).

### 3. INSTALLATION AND FIRST USE





All packing materials used for this unit are suited for recycling.

Before and during unpacking, check the state of the unit. In case of damage, store the packing material, and contact the transporter within fifteen working days after receiving the goods.

#### 3.1 Unpacking the unit

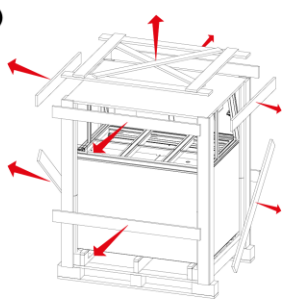
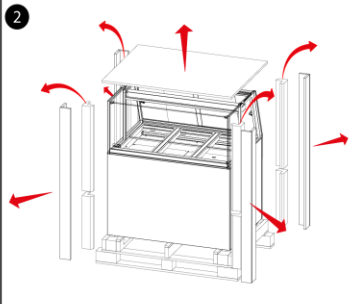
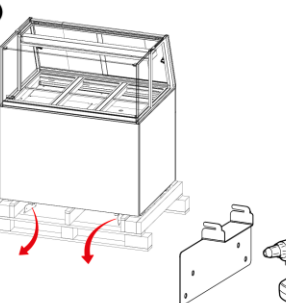
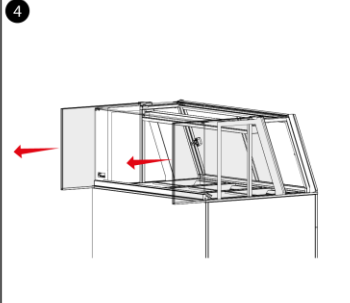
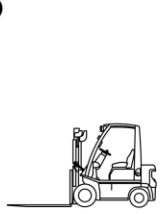
1. Remove the plastic wrapping from the unit.
2. Place the pallet near the desired location.
3. Remove all side & corner beams according to the Unpacking Instructions included in the packaging.
4. Lift the unit off the pallet and place it in the desired location.
5. Remove all remaining packing materials from the unit.
6. Remove the protective foil from the metal parts.

UNPACKING INSTRUCTION DC		9124880 rev. 11/2023
<b>1</b>  Start by removing the top and side beams.	<b>2</b>  Remove the corner beams + eps	
<b>3</b>  Remove brackets below the device (4x).	<b>4</b>  To prevent damage when moving the unit, the side glass can be removed.	
<b>5</b>  <div style="border: 1px solid red; padding: 5px; margin: 5px 0;"> <p style="text-align: center;"><b>Attention!</b></p> <p>Make sure the electric panel and box are out of the way of the forks.</p> <p><b>Note!</b> Always lift a drop-in unit underneath the support frame.</p> </div> Use a reach truck or electric stacker to remove the unit from the pallet.	<b>6</b>  <p>NL - Lees de handleiding voordat u verder gaat.                      EN - Read the manual before proceeding.                      DE - Lesen Sie die Gebrauchsanleitung, bevor Sie Fortfahren.                      FR - Lire le manuel avant de continuer                      ES - Leer el manual antes de continuar                      PT - Leia o manual de instruções antes de continuar.                      IT - Leggere il manuale prima di procedere.                      NO - Les nøye gjennom instruksjonene før du tar apparatet i bruk.                      SV - Läs igenom bruksanvisningen innan du fortsätter.                      FI - Lue käyttöohje ennen kuin otat laitteen käyttöön.</p>	



### 3.2 Installation and positioning



#### WARNING

Electric shock hazard. Grounding instructions: only connect the appliance to an alternating current provided by a grounded wall socket, with a mains voltage in accordance with the information indicated on the identification plate of the appliance.

It is the consumer's responsibility to make sure the electrical installation conforms with current national and local codes and wiring regulations.

Do not use a multi plug or extension cord. Such can result in fire, electrical shock, or other personal injury.

Failure to follow these instructions can result in severe injury or death.



#### WARNING

Position the unit on a flat and horizontal surface. An inclined plane of maximum 5° is allowed during transportation/relocation. Always remove products from the unit prior to moving the unit.

- Place the unit on a sufficiently sturdy floor. Keep the weight of the unit in mind.
- Adjust the length of the unit's legs to level the instrument horizontal see section 3.2.1.
- Be sure that the personnel have sufficient room to operate the unit.
- Keep a distance of at least 150 mm between the wall and the back of the unit.
- While positioning, keep the unit out of children's reach.
- Cold air flow has a negative effect on the performance of the unit, therefore do not position a unit near a doorway, a ventilation device, or a refrigerator. The design of the unit allows for a maximum draft of 0,2 m/s.
- Do not place the unit into direct sunlight.
- Be sure that the minimum ambient temperature is 20°C.
- Connect the unit to a wall socket with the proper mains voltage using the mains plug. A certified electrician must mount the wall socket.
- Keep the plinth free from any obstacles to ensure ventilation.
- Connect the overflow pipe to a fixed drainage (strongly advised if possible).
- For automatic water filled models: Minimum water pressure of 150 kPa. Maximum water pressure of 600 kPa. Recommended water pressure of 150 – 200 kPa.

#### 3.2.1 Level the unit

Place the unit on a sturdy, flat surface, and level the unit by adjusting the unit's legs (max. +15 mm).

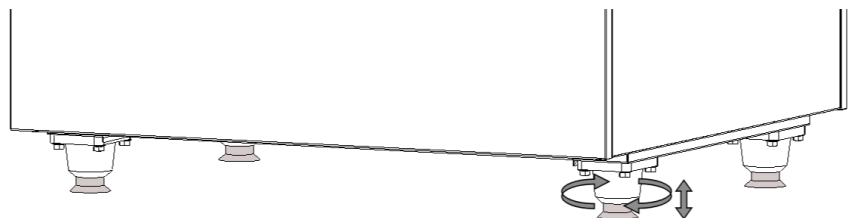

### 3.2.2 Mounting the plinths

Place the rear plinth by attaching it to both rear adjustable legs using its two clamps.

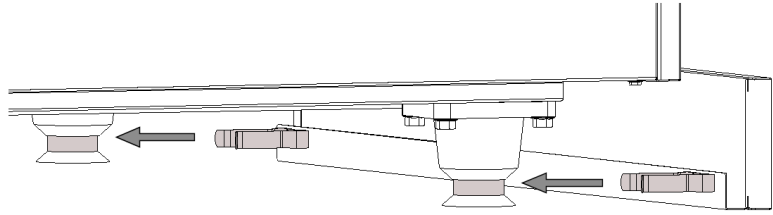

Insert the pegs of both side plinths into the slots of the rear plinth.

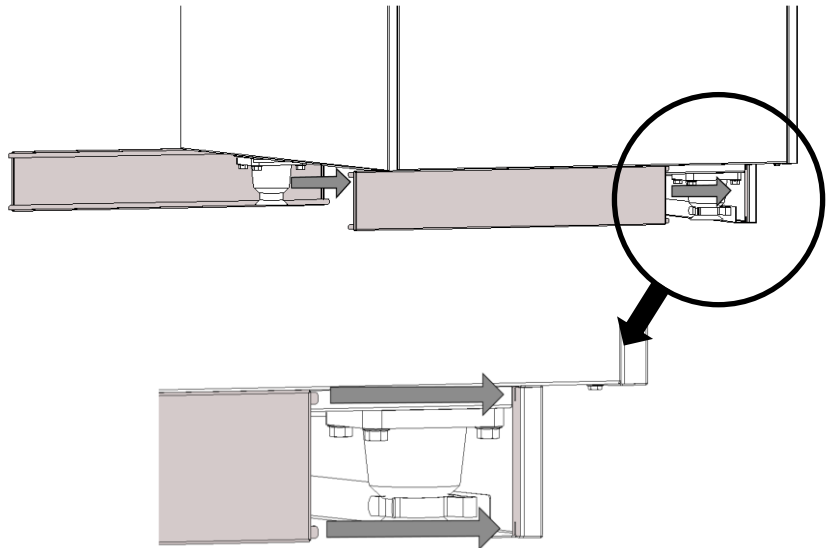

Secure the side plinths by inserting the pegs into the slots of the front plinth, while clamping the front plinth to the front adjustable legs.

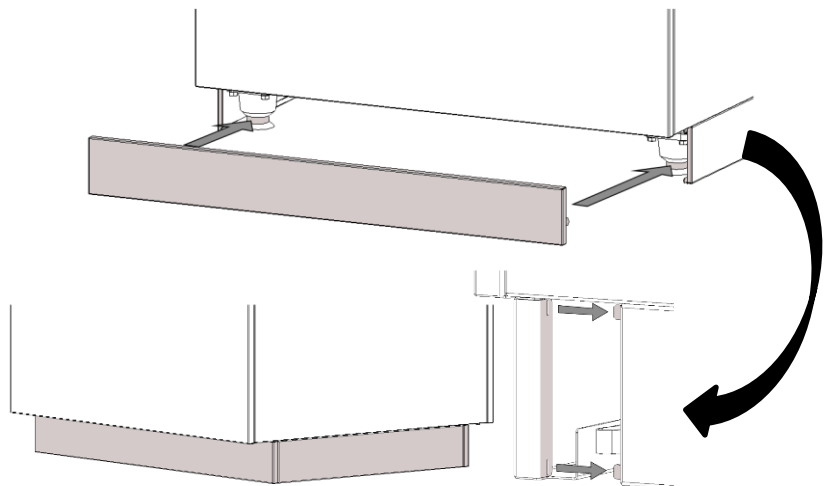

### 3.3 Drop-in units

For installation of the drop-in units refer to instruction 9124892.

### 3.4 Plateau Options

The presentation deck be set at a variety of horizontal levels (I, II, III) and angles (IV, V, VI) as seen in the sideview cross-section for different display experiences. It is possible to use gastronorm pans up to 100 mm deep.

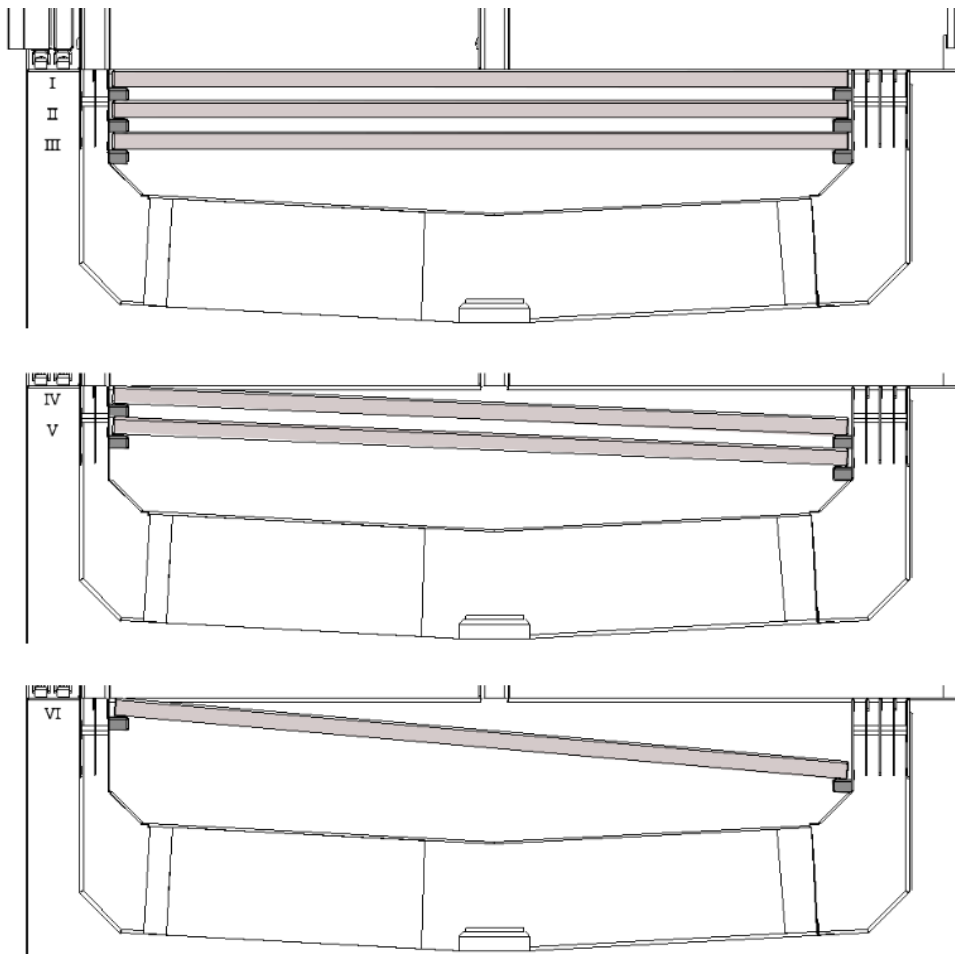

To change to a different position:

- Remove the plateaus from the unit.
- Reposition the supports at the front and/or back to the desired positions.
- Place the plateaus back in the unit.

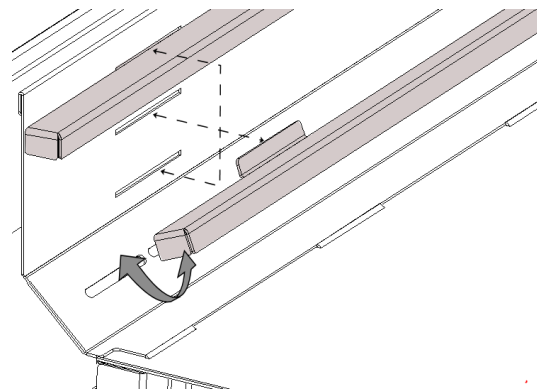

### 3.5 Humidification system

#### 3.5.1 Water connection

When connected to the water supply the water tray will fill automatically when the water level is too low.

How to connect the water supply:

- Remove the front panel screws (when delivered with under frame).
- Remove the front panel.
  
- Connect the water supply hose to  $\frac{3}{4}$ " inlet pipe of the water tray (10 mm connection also possible).
- Replace the front panel and secure it with the screws.

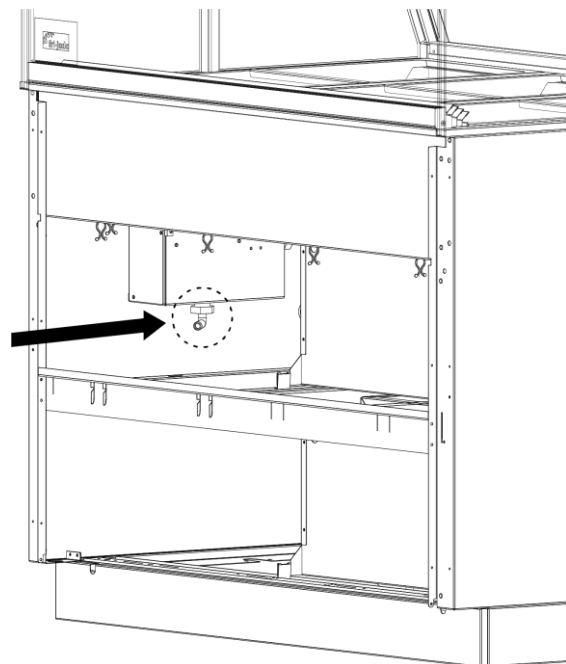

**Limescale filter:**

To reduce the amount of limescale, place a scale filter in the water supply.

### 3.5.2 Manual filling system (optional)

For units that have a manual filling system, a drawer is installed below the control panel, wherein the refillable water tank is placed. This tank can be refilled inside the drawer or it can be taken outside of it by disconnecting the water connection.

Make sure to properly reconnect the water connection when placing it back.

The drawer has been designed to use this water tank without lid.

Close the tilt-clap before slowly closing the drawer.

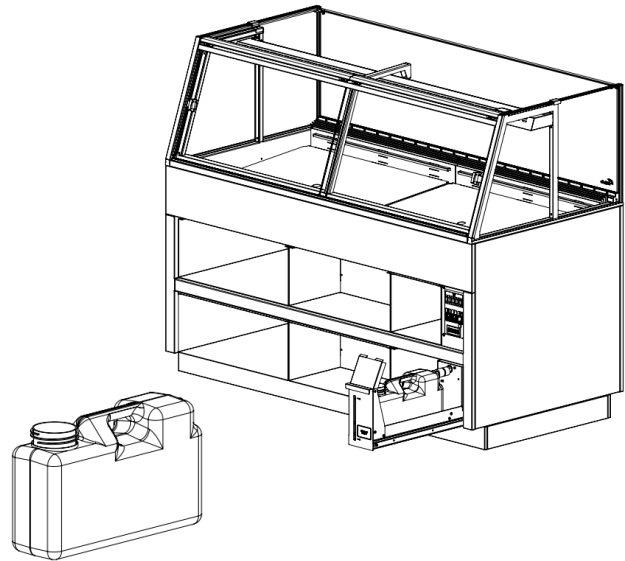

Empty and rinse the water tank at least every 3 days. Make sure there is no soap residue or other detergent before placing the tank back.

### 3.5.3 Water level alarm

- When the water level in the reservoir drops below the minimum level, an alarm light will light up underneath the Humidifier button.

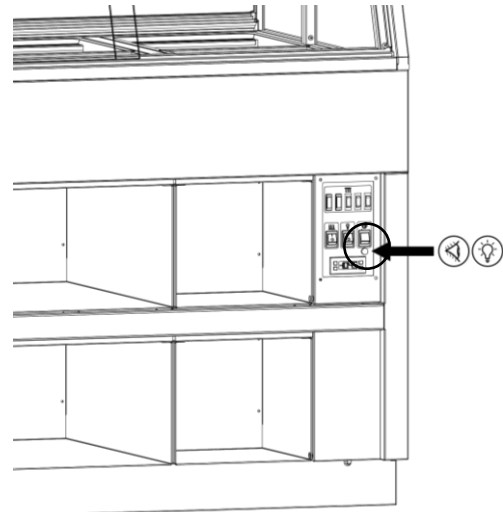

- Fill the water reservoir
- Switch the humidifier alarm button off for 5 seconds and switch it back on
- Check the water supply if the light goes on.

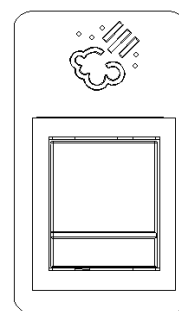

### 3.6 First use

Before starting to use the unit, clean the inside thoroughly with mild detergent and water.

After cleaning it wipe it with a cloth moistened with clean water to remove residual detergent, then dry the entire unit.



**WARNING:**

When filling the water tray for the first time, water may come out of the pipe at high speed. This is the result of trapped air in the pipe or water hose.

## 4. OPERATION AND USE



The display and/or set value is not the product/unit temperature.

### Control Panel

#### On/Off Switches:

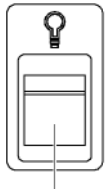

Lighting

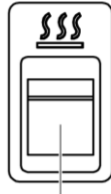

Heating

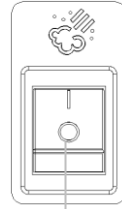

Humidifier

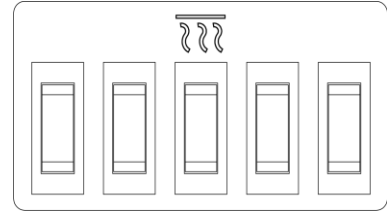

Ceramic heaters\*

\*The number of heater-switches is dependent on the DC model.

### Temperature controller





	Power on/off button*
	UP-button
	DOWN-button
	SET-button



Image for reference only.

\* Switch on/off: hold for at least 10 seconds.

### 4.1 Operating



The unit is set at 85°C intake air temperature. If required, use the control panel to change this temperature.

At an ambient temperature of 20°C and an initial core temperature of 85°C a constant core temperature of 65°C for 4 hours can be maintained.

Ceramic top heaters are available to increase the temperature of specific sections in the unit.

Contact Fri-Jado for advice.

#### Switching-on the unit

1. Switch the heating on.
2. Preheat the unit for approx. 30 minutes.
3. Switch on the lighting.
4. Humidification: apply water supply.

### Loading the unit

- Only place products that have a core temperature of at least 85°C.
- Only package the hot products in bags or containers that are suitable for this purpose.
- To ensure a good contact with the heated trays, only place a single layer of products.
- The maximum carrying-capacity is 15kg per gastronorm section, by equal load.

### Checking the temperature in the unit

- During operation the display of the thermostat shows the temperature at the probe in the unit. The indication ON will light when the elements are active.



Always keep the sliding doors closed as much as possible, or the unit cannot maintain its climate.

An alarm will go off if the temperature gets too low.

### Checking the set temperature

1. Scroll through the folders with the  $\wedge$ -button and the  $\vee$ -button until folder **Pb1**, **Pb2** or **Pb3**.
2. Press **SET** to view the value measured by the corresponding probe.

### Adjusting the set temperature

1. During operation, the display of the thermostat shows the temperature in the unit.
2. Push twice on the **SET**-button. The set temperature will appear on the display.
3. Push the  $\wedge$ -button and the  $\vee$ -button within 15 seconds.
4. Adjust the set temperature by means of the  $\wedge$ -button and the  $\vee$ -button.
5. Push once on the **SET**-button to store the new set temperature.

### Checking the product temperature

- Regularly check the temperature of the product (once every hour is advised).
- Use a digital thermometer to check the temperature.
- Write down the measured values in a log.
- Always use a disinfected thermometer sensor.

### Switching off

1. Remove all products from the unit. In order to avoid temperature-drop of the products, store them in another warm holding unit.
2. Switch the heating off.
3. Switch the lighting off.
4. Close water supply when applicable.

## 5. CLEANING AND MAINTENANCE



### WARNING

Never use a water hose for cleaning. Water can seep into the unit through the ventilation holes of the unit.

Disconnected the appliance from their power supply during cleaning or maintenance and when replacing parts.



Because of hygiene aspects and optimum condition of the unit it is of utmost importance to keep a daily cleaning pattern from first use onwards.

### 5.1 Maintenance schedule

Item	Action	Frequency
Inside	<ul style="list-style-type: none"> <li>• Clean, see section 5.2.</li> </ul>	Daily
Outside	<ul style="list-style-type: none"> <li>• Clean, see section 5.3.</li> <li>• Use Stainless Steel cleaning spray to remove stains and restoring the gloss.</li> </ul>	Weekly
Glass panes	<ul style="list-style-type: none"> <li>• Clean, see section 5.4.</li> </ul>	Weekly
Bottom air guides	<ul style="list-style-type: none"> <li>• Clean, see section 5.5.</li> </ul>	Weekly
Humidifier	<ul style="list-style-type: none"> <li>• Remove any calcium build-up in the water tray and on the pins of the water level sensor. Example detergent: hot water and vinegar. See section 5.5.</li> </ul>	Weekly

### 5.2 Daily Cleaning

- Clean the inside of the unit with hot water and a suitable cleaner.
- After cleaning wipe, the inside with a clean wet cloth. Rinse off all detergent before using the unit again.

### 5.3 Weekly Cleaning



### WARNING

Only use a damp cloth to clean the control panel.

- Clean the outside of the unit with a small amount of hot water and a mild cleanser and using a soft brush or sponge. After cleaning it, dry the outside with a cloth.
- Treat all cleaned surfaces with a suitable antibacterial agent.
- Rub dry with a soft cloth or a paper towel.



## 5.4 Cleaning Glass Panes

Use a mild detergent and soapy water for the cleaning of the unit.

To assist with the cleaning of the unit, it is possible to open glass windows of the unit.

Lift the top window first before opening the front window

Always lower the top window slowly and do not drop it.

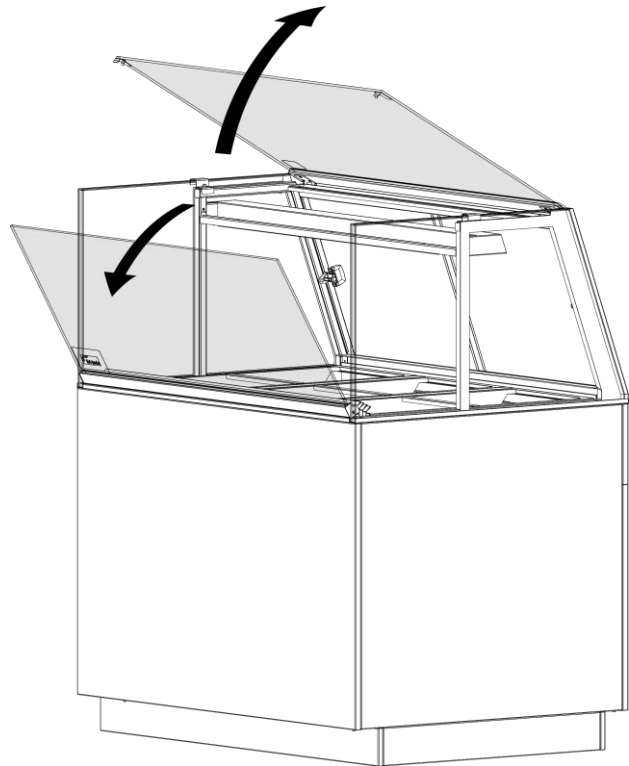

It is possible to remove the side, front and sliding windows of the unit.

Place the windows on a soft cloth to prevent damage while removed from the unit.

Put the windows back in the unit before turning the unit on again.

Place any windows back into the unit in reverse order of removing them.

Always move carefully and do not use excessive force to place the windows back.

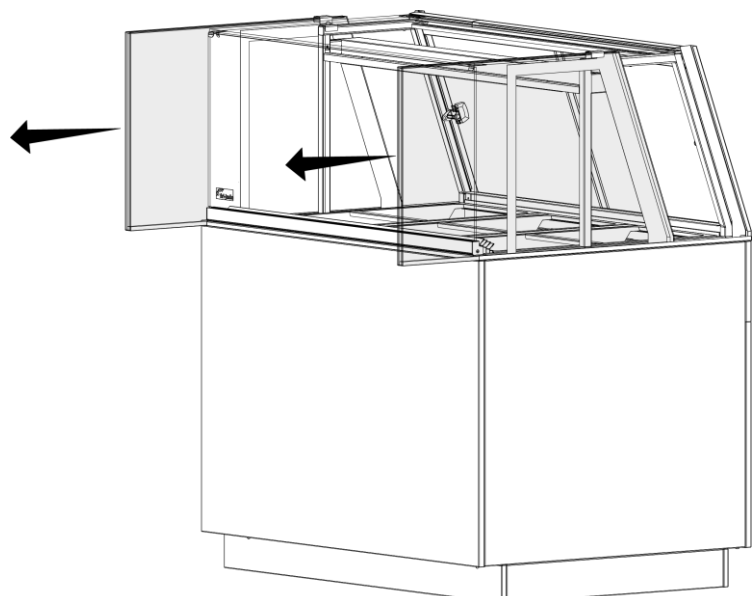

The side windows are removable by sliding them out the frame.

Clean the bottom guides.

The sliding windows are removable by:

- Lifting them up
- Tilting them outwards
- Removing them from the guides

Clean the bottom guide of the windows. These are removable for cleaning if required.

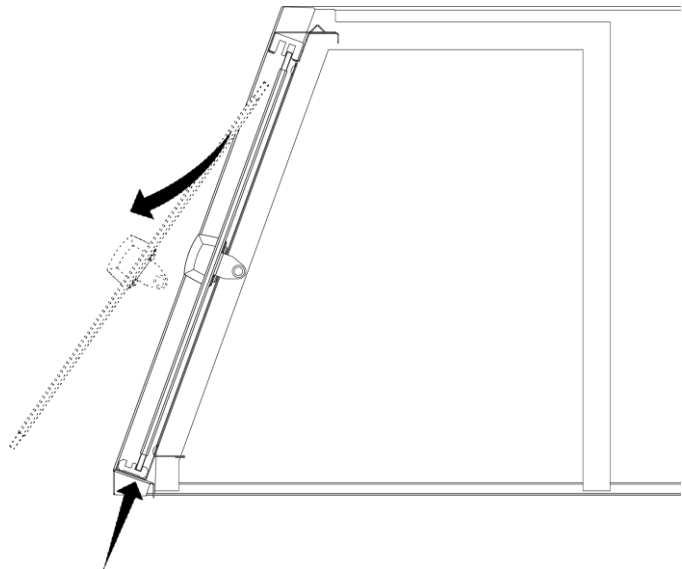

### 5.5 Cleaning air guides, fans, and water tray



**WARNING**

Switch off the unit first and let it cool down.  
Be aware of rotating parts.

Be aware that high humidity levels may encourage the growth of biological organisms in the environment.

Remove the GN-pans and clean these.

Take out the GN-frames.

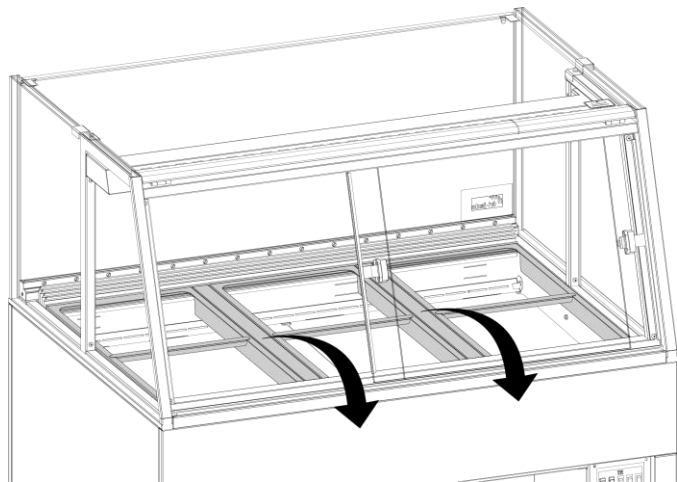

Remove first the plating of the lower presentation deck.

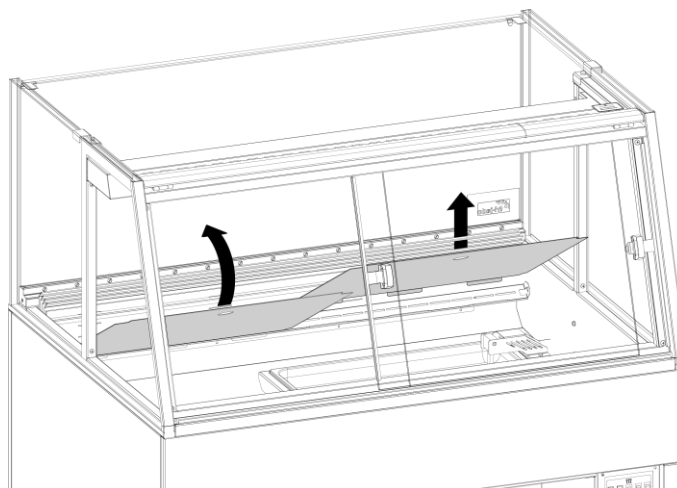

At the front and the back of the unit there are removable air guides.

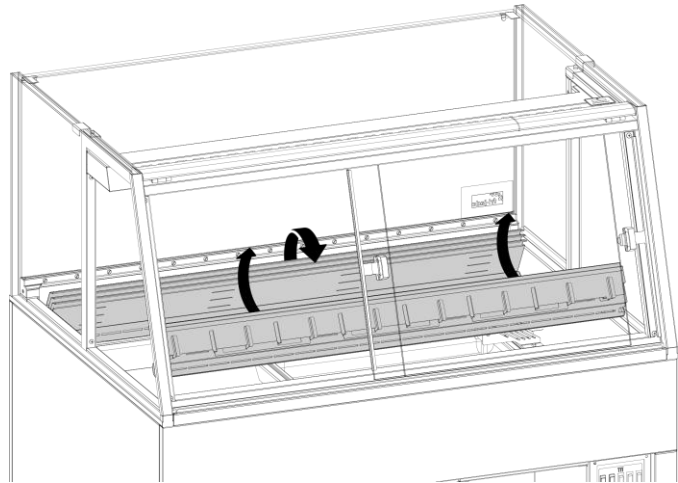

It is possible to remove the fins of air guides and clean them separately.

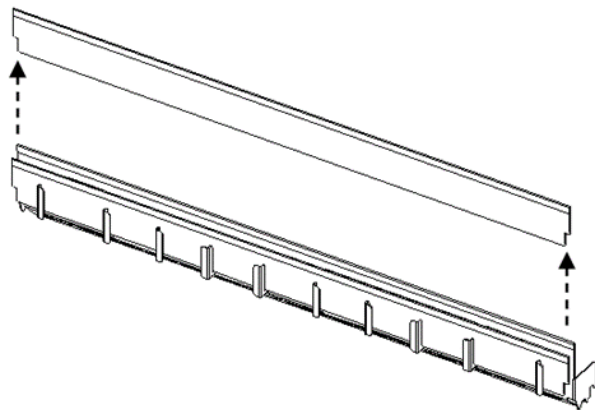

Tilt the fan-box at the back to clean below it.

It is possible to remove the water evaporation pan and clean it separately.

**NOTE:** Be sure to position the water level sensor pins back into the evaporation pan.

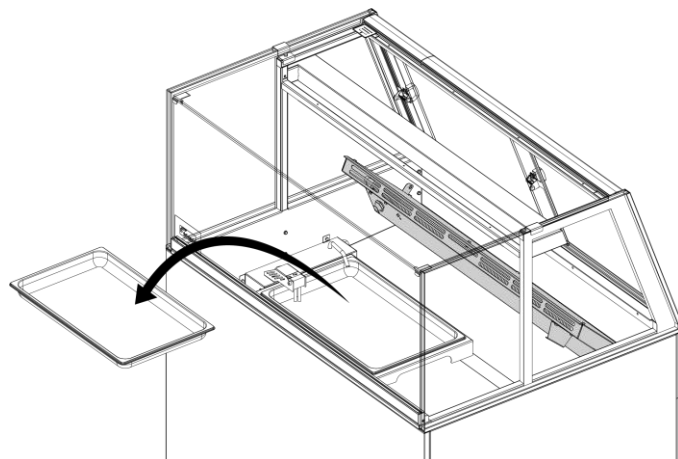

## 6. MALFUNCTIONS AND SERVICE

Before consulting the dealer or the service agency when there is a fault, check the following points:

- Is the power supply OK? Check the fuses and the earth leakage switch in the meter cupboard.
- Are all the switches in the correct position?

Item	Malfunction	Action
Unit	Unit does not work	<ul style="list-style-type: none"> <li>• Check the power supply.</li> <li>• Are all switches in the correct position?</li> </ul>
Unit	Display shows error code	<ul style="list-style-type: none"> <li>• Contact the supplier or service agency.</li> </ul>
Lamp	Does not light up	<ul style="list-style-type: none"> <li>• Switch ON.</li> </ul>
Humidifier	Warning light humidifier	<ul style="list-style-type: none"> <li>• Check water level/supply.</li> <li>• Reset by pushing the switch for at least 5 seconds.</li> </ul>
Mains cord	Damaged	<ul style="list-style-type: none"> <li>• Replace, see section 6.1.</li> </ul>
Window	Damaged	<ul style="list-style-type: none"> <li>• Replace, contact the supplier or service agency.</li> </ul>

### 6.1 Replace the mains cord



**WARNING**

Hazardous electrical voltage.

Immediately contact the supplier or service agent to replace a damaged power cord. Never turn the unit on when the power cord is damaged.

## 7. TECHNICAL SPECIFICATIONS

**WARNING**

Consult the identification plate to get the proper specifications of the unit. The electrical data may vary from country to country.

Model		120-4.3	150-4.3	180-4.3
Length incl. end walls	mm	1200	1500	1800
Length excl. end walls	mm	1150	1450	1750
Depth excl. worktop	mm	890		
Height on stand	mm	1420		
Underframe height	mm	900		
Drop-in cut out (W x D)	mm	1167 x 865 (+/- 5)	1467 x 865 (+/- 5)	1767 x 865 (+/- 5)
Voltage	V	1N~ 230	3N~ 400/230	3N~ 400/230
Current	A	13,8	14,2	8,5
Frequency	Hz	50/60		
Weight (net) *	kg	198	239	283
Weight (gross) *	kg	248	289	333
Packaging dimensions (W x D x H)	mm	980 x 1060 x 1673	1280 x 1060 x 1673	1680 x 1060 x 1673
Product deck dimensions	mm (W x D)	1100 x 730	1400 x 730	1700 x 730
	m <sup>2</sup>	0,80	1,02	1,24
Gastronorm capacity	GN	3x 4/3	4x 4/3	5x 4/3
Max. gastronorm pan depth	mm	100		

\* Drop-in units minus approx. 45 kg

<Notes>

<Notes>

Fri-Jado B.V.  
Blauwhekken 2  
4751 XD Oud Gastel  
The Netherlands  
Tel: +31 (0) 76 50 85 400

Fri-Jado Inc.  
1401 Davey Road, Suite 100  
Woodridge IL 60517  
USA  
Tel: +1-630-633-7950

[www.frijado.com](http://www.frijado.com)